

NPN General Purpose Amplifier

BCW71/BCW72

FEATURES

- Super Mini Packaged Transistor for Hybrid Circuits.



APPLICATIONS

- General purpose switching and amplification.
- For Complementary with PNP Type BCW69/70.

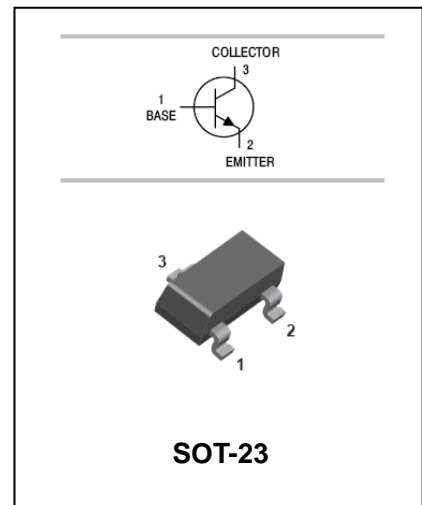

ORDERING INFORMATION

Type No.	Marking	Package Code
BCW71	K1	SOT-23
BCW72	K2	SOT-23

MAXIMUM RATING @ Ta=25°C unless otherwise specified

Symbol	Parameter	Value	Unit
V _{CB0}	Collector-Base Voltage	50	V
V _{CEO}	Collector-Emitter Voltage	45	V
V _{EBO}	Emitter-Base Voltage	5	V
I _C	Collector Current -Continuous	100	mA
P _D	Total power Dissipation	200	mW
T _j , T _{stg}	Junction and Storage Temperature	-65 to +150	°C



NPN General Purpose Amplifier

BCW71/BCW72

ELECTRICAL CHARACTERISTICS @ Ta=25°C unless otherwise specified

Parameter	Symbol	Test conditions	MIN	Typ	MAX	UNIT
Collector-base breakdown voltage	$V_{(BR)CBO}$	$I_C=10\mu A$ $I_E=0$	50			V
Collector-emitter breakdown voltage	$V_{(BR)CEO}$	$I_C=2mA$ $I_B=0$	45			V
Emitter-base breakdown voltage	$V_{(BR)EBO}$	$I_E=10\mu A$ $I_C=0$	5			V
Collector cut-off current	I_{CBO}	$V_{CB}=20V$ $I_E=0$ $V_{CB}=20V$ $I_E=0, T_a=100^\circ C$			100 10	nA μA
DC current gain	BCW71 BCW72	h_{FE} $V_{CE}=5V$ $I_C=2mA$	110 200		220 450	
Collector-emitter saturation voltage	$V_{CE(sat)}$	$I_C=10mA$ $I_B=0.5mA$			0.25	V
Base-emitter saturation voltage	$V_{BE(sat)}$	$I_C=10mA$ $I_B=0.5mA$ $I_C=50mA$ $I_B=2.5mA$		0.75 0.87		V
Base-emitter voltage	V_{BE}	$I_C=2mA$ $V_{CE}=5V$	0.55		0.7	V
Collector output capacitance	C_{ob}	$I_E=I_e=0, V_{CB}=10V, f=1MHz$			4.0	pF
Transition frequency	f_T	$V_{CE}=5V$ $I_C=10mA$ $f=100MHz$		300		MHz
Noise figure	NF	$V_{CE}=5V$ $I_C=200\mu A$ $R_S=2k\Omega$ $f=1kHz$ $B=200Hz$			10	dB

TYPICAL CHARACTERISTICS @ Ta=25°C unless otherwise specified

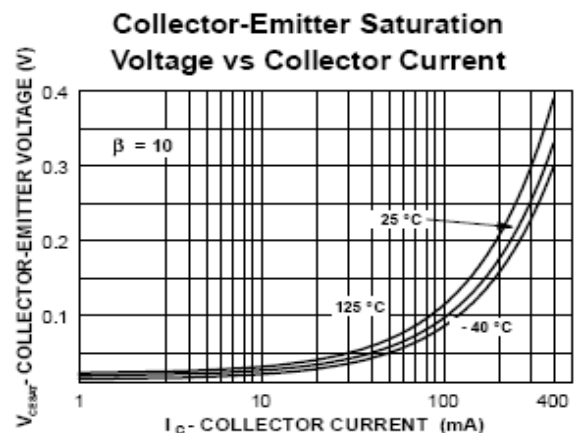
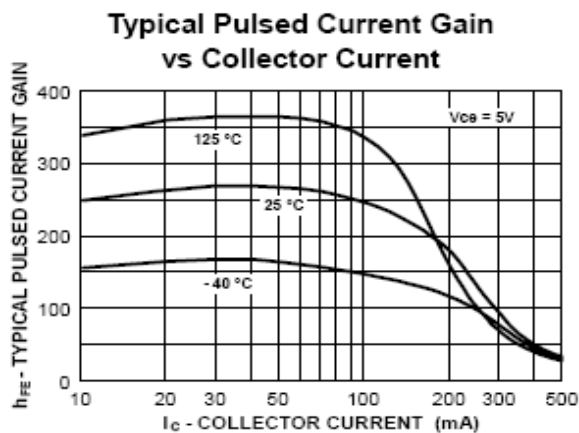



NPN General Purpose Amplifier

BCW71/BCW72

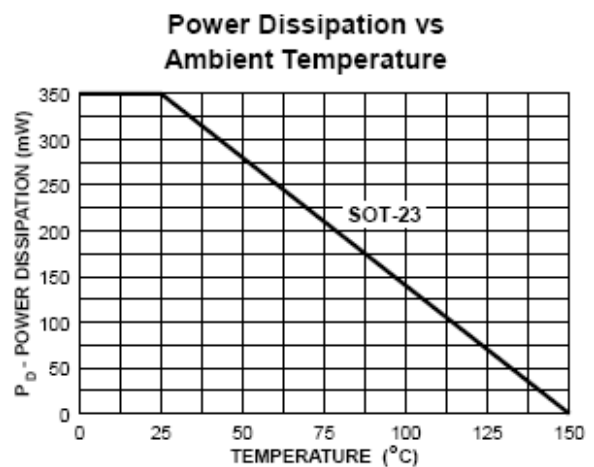
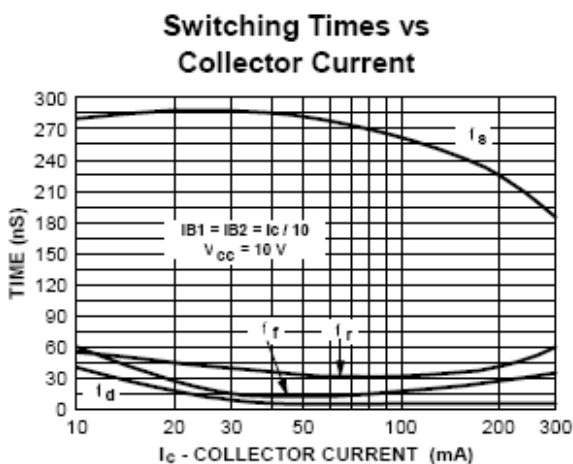
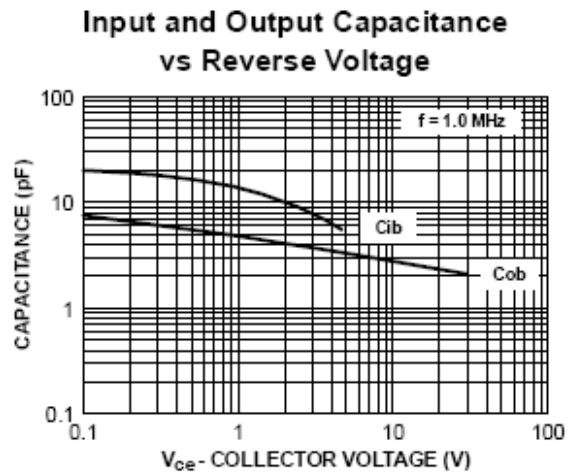
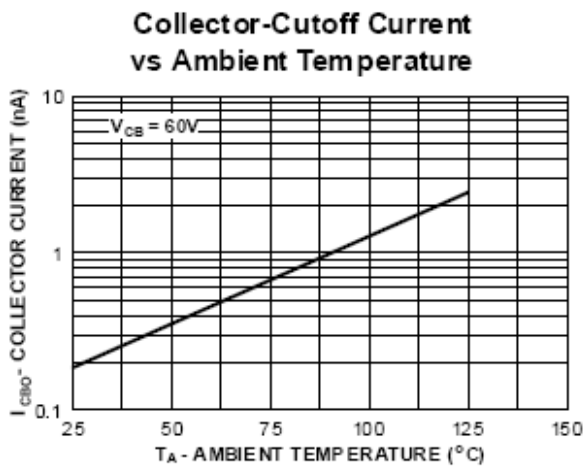
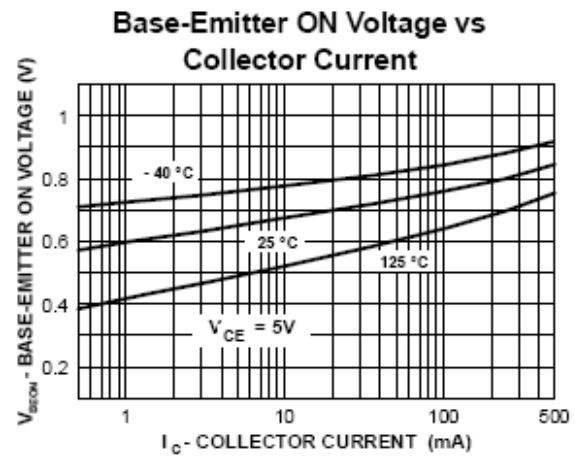
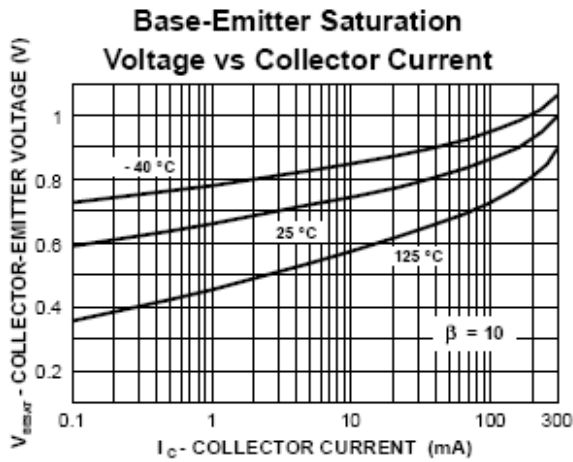

NPN General Purpose Amplifier

BCW71/BCW72

PACKAGE OUTLINE

Plastic surface mounted package

SOT-23

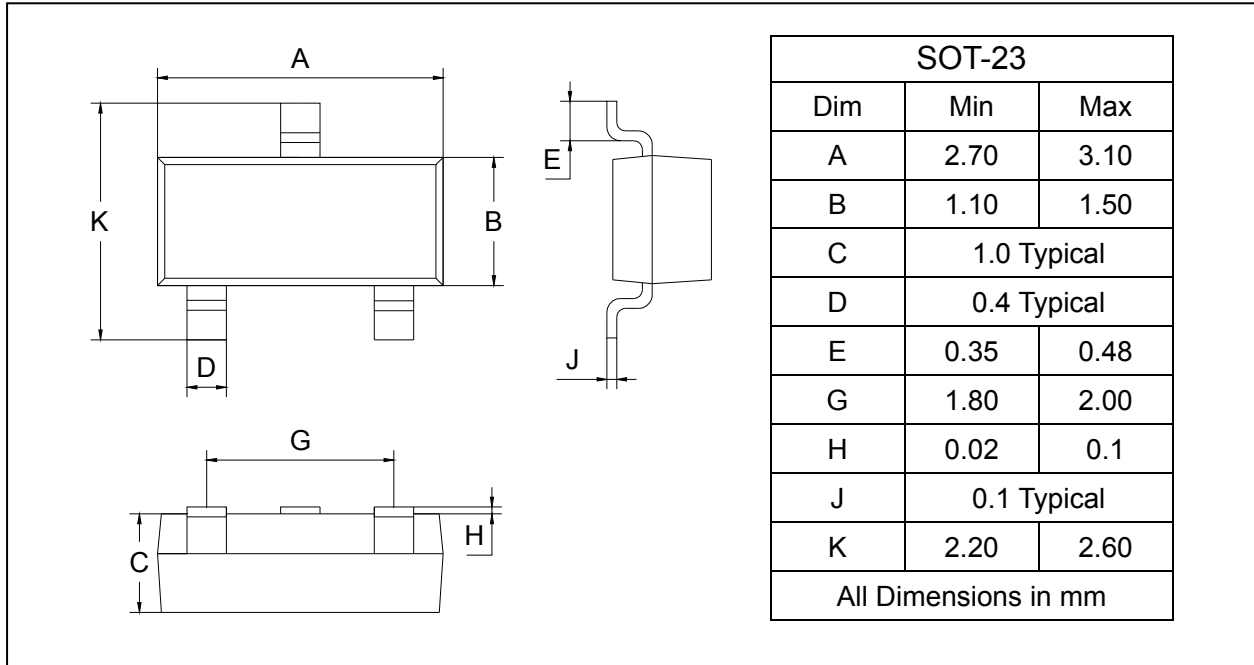

SOLDERING FOOTPRINT

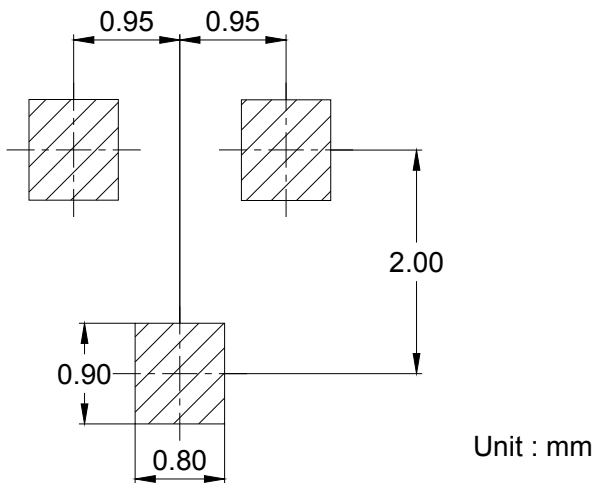

PACKAGE INFORMATION

Device	Package	Shipping
BCW71/72	SOT-23	3000/Tape&Reel